

## PERFECTION GEAR • **AT SERIES ROTATION SWING DRIVES**

Perfection Gear's AT Series Worm Gear Speed Reducers are hydraulically driven swing drives. These quality made products are commonly used as a rotation drive for booms, but could be used in any application where speed reduction is required.

### Key Features

- Withstands High Shock Loads
- Optional Electric Motor Driven Swing Drives
- Solid Bronze Gears
- Hardened Steel Worm
- Tapered Roller Bearing
- Optional Crowned Pinion

### Technical Information

Size:	2.63" to 5.17" Center Distance
Ratio	15:1 to 50:1 or Per Customer Specification
Output Torque (in-lbs):	8,000 to 45,000 Capacity 22,000 to 150,000 Output Yield
Output Pinion/Shaft:	Per Customer Specification
Input Option:	SAE "A" Mount; 2 Bolt, Keyed or Splined
Other Specifications:	Eccentric Ring Per Customer Specification
Applications List:	Man-Lifts, Utility Trucks, Cranes, Boom Trucks, Truck-Mounted Cranes, Tree-Trimming Vehicles, Fire & Rescue Vehicles and Service Trucks



The Perfection Gear brand has a solid reputation of building exceptionally tough aerial swing drive products that can stand up to harsh outdoor conditions and high shock loads that are common to crane usage and boom type work vehicles.

# PERFECTION GEAR • AT SERIES ROTATION SWING DRIVES

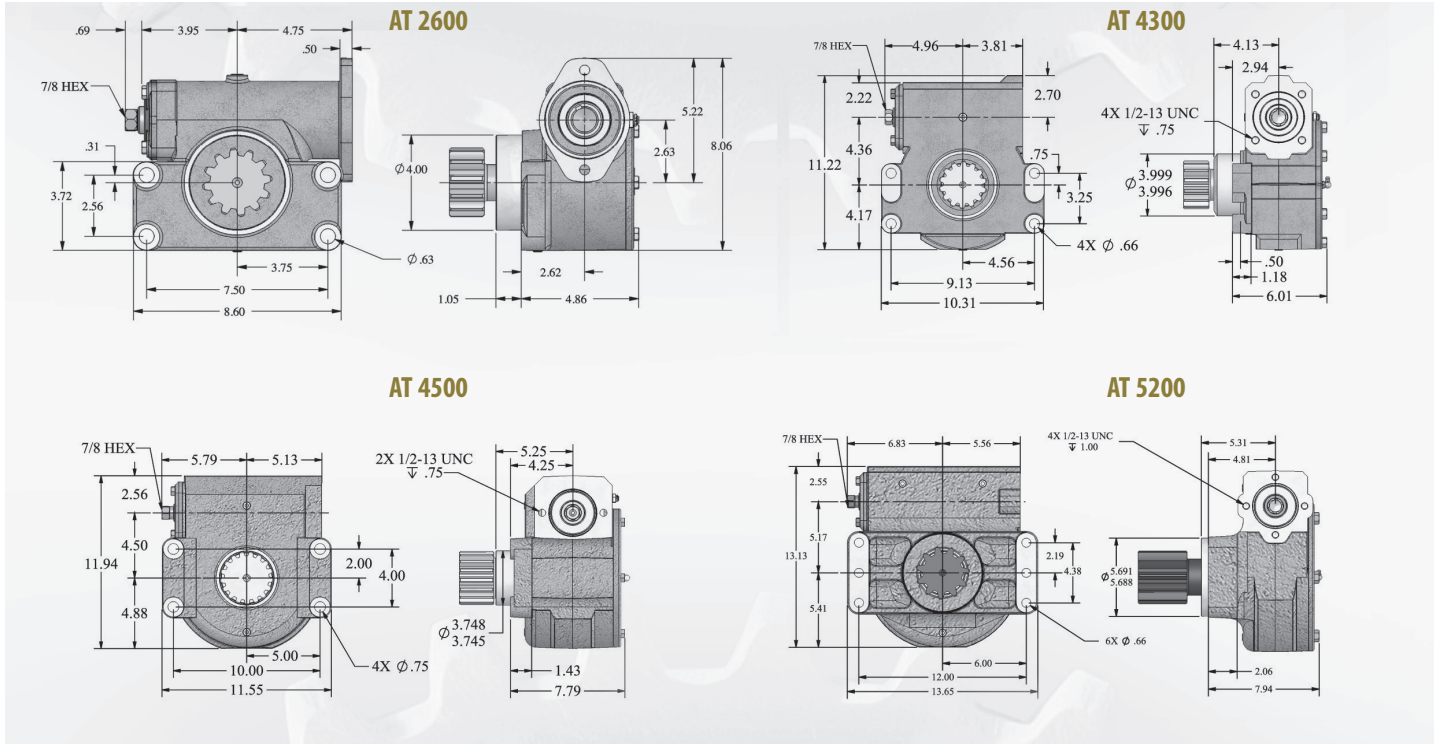

Model Series	Speed Reducer	Ratio	Rating (in-lbs.)	Weight	Output Pinion	Eccentric Ring	Hydraulic Motor Mount
AT 2600	2.63" Center Distance	30:1 or per Customer Specification	8,000 - Output Capacity 22,000 - Output Yield	36 lbs.	Per Customer Specification	Optional	SAE "A" Mount 2 Bolt, Keyed or Splined
AT 4300	4.36" Center Distance	32:1, 39:1 or per Customer Specification	15,000 - Output Capacity 80,000 - Output Yield	72 lbs.	Per Customer Specification	Optional	SAE "A" Mount 2 Bolt, Keyed or Splined
AT 4500	4.50" Center Distance	15:1, 18:1, 25:1, 30:1, 39:1, 44:1 or per Customer Specification	30,000 - Output Capacity 100,000 - Output Yield	135 lbs.	Per Customer Specification	Optional	SAE "A" Mount 2 Bolt, Keyed or Splined
AT 5200	5.17" Center Distance	25:1, 30:1, 44:1, 50:1 or per Customer Specification	45,000 - Output Capacity 150,000 - Output Yield	173 lbs.	Per Customer Specification	Optional	SAE "A" Mount 2 Bolt, Keyed or Splined

HBD Industries Inc. and its subsidiaries cannot accept responsibility for possible errors in catalogues, brochures, other printed materials, and website information, and may change, delete, add to or otherwise modify such information without notice. HBD reserves the right to alter its products without notice, including products already on order, provided that such alteration can be made without changes being necessary in specifications already agreed to. All trademarks in this material are the property of the HBD Industries Inc., or its subsidiaries. The HBD and HBD brands logotype, are trademarks of HBD Industries Inc. All rights reserved.

DISTRIBUTED BY:

HBD/WINSMITH, INC.  
 PERFECTION GEAR  
 9 NORTH BEAR CREEK ROAD  
 ASHEVILLE, NC 28806  
 TEL: 1 (828) 253-0000  
 TEL: 1 (828) 253-2649  
 www.perfectiongear.com